

Application:

Stainless steel expansion joint for compensating movements and misalignments in dry exhaust systems.
Maximum operating temperature +550 °C, maximum working pressure 2,5 bar (20 °C).

Description:

Stainless steel expansion joint AISI 321. Double ply bellows.
Carbon steel weld ends.

Construction and Design:

- Stainless steel expansion joint AISI 321
- Double ply bellows material
- Standard length
- Carbon steel weld ends
- Max. temperature: 550 °C
- Max. pressure: 2,5 bar (20 °C)
- Stock item

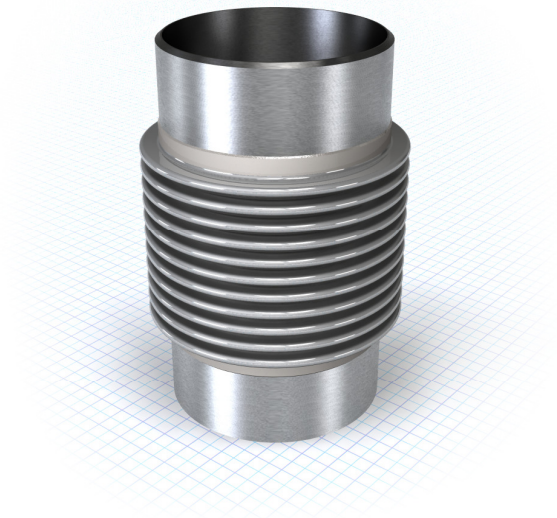
**Approvals:**

BUREAU VERITAS



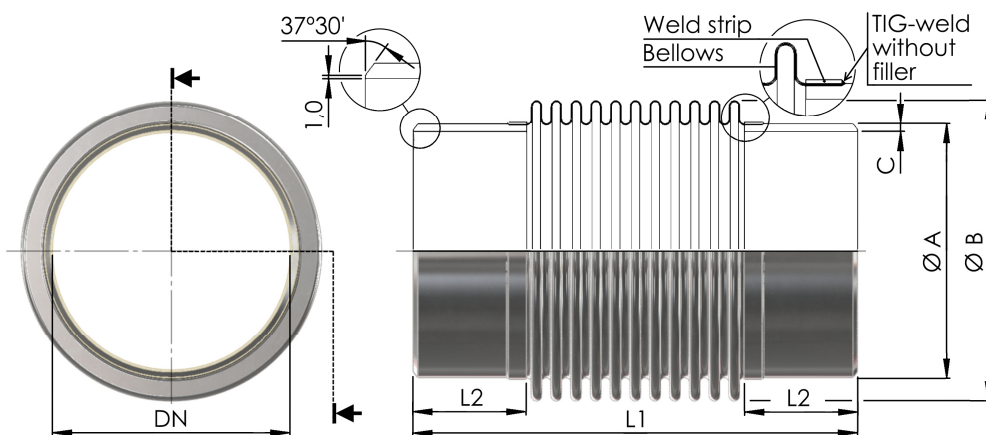

Technical data:

Article no.	DN	L1	Bellows (Material: AISI 321)			Welding ends (Material: Carbon steel)			Movements mm		Springrate N/mm	
			B	Plies	Thickness	A	C	L2	Axial +/-	Lateral +/-	Axial +/-	Lateral +/-
330 000 025	25	205	42,0	1	0,2	33,7	2,9	45	28	15	18	57
330 000 032	32	205	52,0	1	0,3	42,4	2,6	50	28	15	50	186
330 000 040	40	205	60,3	1	0,3	48,3	2,6	50	28	15	36	143
330 000 050	50	245	78,3	2	0,3	60,3	2,9	63	28	15	49	214
330 000 065	65	245	96,7	2	0,3	76,1	2,9	63	28	14	40	206
330 000 080	80	245	109,7	2	0,3	88,9	3,2	63	28	13	46	261
330 000 090	90	245	122,2	2	0,3	101,6	3,2	63	35	10	46	337
330 000 100	100	245	140,5	2	0,3	114,3	3,6	63	35	10	35	281
330 000 125	125	245	165,7	2	0,3	139,7	3,6	63	35	9	42	389
330 000 150	150	245	200,5	2	0,3	168,3	4,0	63	35	9	35	365
330 000 175	175	245	225,9	2	0,3	193,7	4,5	63	35	9	35	365
330 000 200	200	245	251,1	2	0,3	219,1	4,5	63	35	6	43	610
330 000 250	250	245	305,2	2	0,3	273,0	5,0	63	35	5	54	924
330 000 300	300	295	360,9	2	0,3	323,9	5,6	75	40	6	42	698
330 000 350	350	295	392,6	2	0,3	355,6	5,6	75	40	5	48	870
330 000 400	400	295	443,4	2	0,3	406,4	5,6	75	40	3	52	1157

Subject to alteration

Movements are not in combination

Loggers b.v.

Mail: P.O. Box 194 3300 AD Dordrecht The Netherlands
Office: Pieter Zeemanweg 133 3316 GZ Dordrecht The Netherlands
Tel. +31(0) 78 618 28 44
Fax. +31(0) 78 618 06 50
Email: sales@loggers.nl
Internet: www.loggers.nl

Loggers Schwingungstechnik GmbH

Mail and office:
Am Markt 9 D-27419 Sittensen Germany
Tel. +49(0) 4282 5949 0
Fax. +49(0) 4282 5949 39
Email: sales@loggers.de
Internet: www.loggers.de